

HOCHLEISTUNGS-GELENKKÖPFE
Mit fixiertem Gleitlager,
Maßreihe E / EH, Innengewinde,
Anschlussmaße nach DIN ISO
12240-4 und DIN ISO 8139

HEAVY-DUTY ROD ENDS
 With pressed spherical plain bearing, series E / EH, female thread, according to DIN ISO 12240-4 and thread according to DIN ISO 8139

- **Sonderanfertigungen auf Anfrage**
 - Custom made products on request

Gehäuse:
 Geschmiedeter Einsatzstahl vergütet, Oberfläche galvanisch verzinkt, Cr VI-frei
Außenring:
 Wälzlagerstahl gehärtet, geschliffen, phosphatiert, an Sollbruchstelle gesprengt, mit Schmiernut und -bohrung
Gelenkkugel:
 Wälzlagerstahl gehärtet, geschliffen, phosphatiert
Wartung:
 Wartungspflichtig - Im Anlieferungszustand geölt - Erstschmierung durch Anwender
Schmiernippel:
 Trichterschmiernippel DIN 3405 D1/A (ab Größe 15 bis 17), Kegelschmiernippel DIN 71 412 H1 (ab Größe 20 bis 60), weitere Schmiernippel siehe Seite 063
Toleranzen:
 Seite 050 - 057

Housing:
 Forged steel, tempered, surface galvanized, free of Cr VI
Outer ring:
 Ball bearing steel, hardened, ground, phosphated, single split, oil groove and drill holes
Joint ball:
 Ball bearing steel, hardened, ground, phosphated
Maintenance:
 Maintenance required, oiled on delivery, initial lubrication by the user
Grease nipple:
 DIN 3405 D1/A (sizes 15 to 17)
 DIN 71 412 H1 (sizes 20 to 60)
 Further grease nipple see on page 063
Tolerances:
 Page 050 - 057

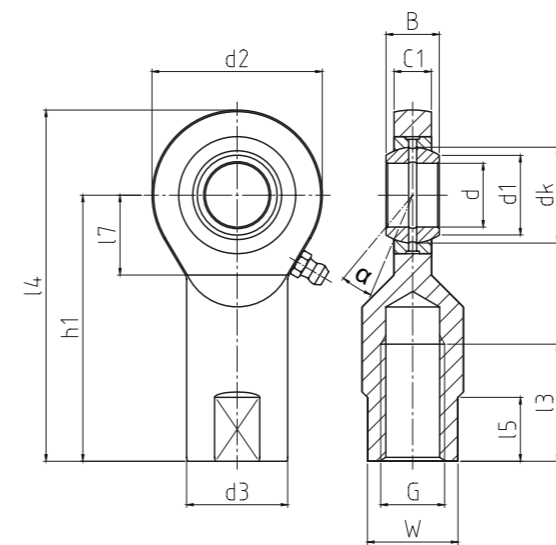

EFN

Hochleistungs-Gelenkköpfe
 Heavy-duty rod ends

CLASSIC Line X

Bestellnummer Order number			Abmessungen Measurements [mm]															Kippwinkel Tilt angle	Gewicht Weight	Tragzahlen Basic load rating		Radiale Lagerluft Radial clearance	
Typ Type	Rechtsgewinde Right hand thread	Linksgewinde Left hand thread	d	G	B	C1	h1	d1	d2	d3	dk	l3	l4	l5	l7	W	α [°]	[kg]	dyn C [kN]	stat Co [kN]	CN [µm]	d	
EFN 06 - 20	-501	-502	6	M 6	6	4	30	8	20	10	10	12	40	8,5	11	9	13	0,021	2,5	8,5	32 - 68	6	
EFN 08 - 20	-501	-502	8	M 8	8	5	36	10	23	13	13	16	47,5	10,5	12	11	15	0,039	4,2	13	32 - 68	8	
EFN 10 - 20	-501	-502	10	M 10	9	6	43	13	28	16	16	20	57	10,5	13	14	12	0,061	6,4	17,8	32 - 68	10	
EFN 10 - 21	-501	-502	10	M 10 x 1,25	9	6	43	13	28	16	16	20	57	10,5	13	14	12	0,061	6,4	17,8	32 - 68	10	
EFN 12 - 20	-501	-502	12	M 12	10	7	50	15	32	19	18	22	66	12,5	15	17	11	0,096	9,2	24,5	32 - 68	12	
EFN 12 - 21	-501	-502	12	M 12 x 1,25	10	7	50	15	32	19	18	22	66	12,5	15	17	11	0,096	9,2	24,5	32 - 68	12	
EFN 15 - 20	-501	-502	15	M 14	12	9	61	18	38	22	22	25	80	12,5	18	19	8	0,18	13,4	36	40 - 82	15	
EFN 17 - 20	-501	-502	17	M 16	14	10	67	20	44	25	25	28	89	16,5	20	22	10	0,22	19,2	45	40 - 82	17	
EFN 17 - 21	-501	-502	17	M 16 x 1,5	14	10	67	20	44	25	25	28	89	16,5	20	22	10	0,22	19,2	45	40 - 82	17	
EFN 20 - 20	-501	-502	20	M 20 x 1,5	16	12	77	24	51	28	29	33	102,5	17,5	23	24	9	0,35	25,2	60	40 - 82	20	
EFN 25 - 20	-501	-502	25	M 24 x 2	20	16	94	29	62	35	35,5	42	125	19,5	30	30	7	0,64	42,4	83	30 - 100	25	
EFN 30 - 20	-501	-502	30	M 30 x 2	22	18	110	34	70	42	40,7	51	145	19,5	32	36	6	0,93	54,0	110	30 - 100	30	
EFN 35 - 20	-501	-502	35	M 36 x 3	25	20	125	39	82	51	47	61	166	24,5	38	41	6	1,3	70,4	146	30 - 100	35	
EFN 35 - 21	-501	-502	35	M 36 x 2	25	20	130	39	82	51	47	66	171	24,5	38	41	6	1,3	70,4	146	30 - 100	35	
EFN 40 - 20	-501	-502	40	M 42 x 3	28	22	145	45	92	60	53	71	191	24,5	42	50	7	2	86	180	40 - 120	40	
EFN 40 - 21	-501	-502	40	M 39 x 3	28	22	142	45	92	52	53	66	188	24,5	42	46	7	1,8	86	180	40 - 120	40	
EFN 45 - 20	-501	-502	45	M 45 x 3	32	25	165	50	102	67	60	76	216	29,5	50	55	7	2,5	107	240	40 - 120	45	
EFN 45 - 21	-501	-502	45	M 42 x 3	32	25	145	50	102	58	60	66	196	29,5	50	50	7	1,9	107	240	40 - 120	45	
EFN 50 - 20	-501	-502	50	M 52 x 3	35	28	195	55	112	72	66	89	251	30,5	60	60	6	3,5	132	290	40 - 120	50	
EFN 50 - 21	-501	-502	50	M 45 x 3	35	28	160	55	112	62	66	69	216	30,5	60	55	6	3	132	290	40 - 120	50	
EFN 60 - 20	-501	-502	60	M 60 x 4	44	36	225	66	135	84	80	103	292,5	33,5	70	70	6	5,5	208	450	40 - 120	60	
EFN 60 - 21	-501	-502	60	M 52 x 3	44	36	175	66	135	71	80	71	242,5	33,5	70	60	6	4	208	450	40 - 120	60	
EFN 70 - 20	-501	-502	70	M 72 x 4	49	40	265	77	162	92	92	72	346,0	35	88	80	6	11	315	850	72 - 142	70	
EFN 70 - 21	-501	-502	70	M 56 x 4	49	40	200	77	162	80,5	92	56	281,0	35	88	70	6	8	315	850	72 - 142	70	