

**HOCHLEISTUNGS-GELENKKÖPFE**  
**Mit integrierter Gleitlagerung,**  
**Maßreihe K, Außengewinde,**  
**Anschlussmaße nach DIN ISO**  
**12240-4**

HEAVY-DUTY ROD ENDS  
 With integral spherical-plain  
 bearing, series K, male thread,  
 according to DIN ISO 12240-4

→ **Sonderanfertigungen auf Anfrage**  
 → Custom made products on request

**Gehäuse:**  
 Geschmiedeter Einsatzstahl, vergütet,  
 Gewinde gerollt, Oberfläche galvanisch ver-  
 zinkt, Cr VI-frei  
**Lagerschale DURBAL-Glide:**  
 Polyamid-PTFE-Glasfaser-Compound  
**Gelenkkugel:**  
 Wälzlagerstahl, gehärtet, geschliffen, poliert,  
 Lauffläche hartverchromt  
**Wartung:**  
 Wartungsfrei  
**Toleranzen:**  
 Seite 050 – 057

**Housing:**  
 Forged steel, tempered, rolled thread, surface  
 galvanized, free of Cr VI  
**Race DURBAL-Glide:**  
 Polyamid-PTFE-fibreglass-Compound  
**Joint ball:**  
 Ball bearing steel, hardened, ground,  
 polished and hard chromium plated  
**Maintenance:**  
 Maintenance-free  
**Tolerances:**  
 Page 050 – 057

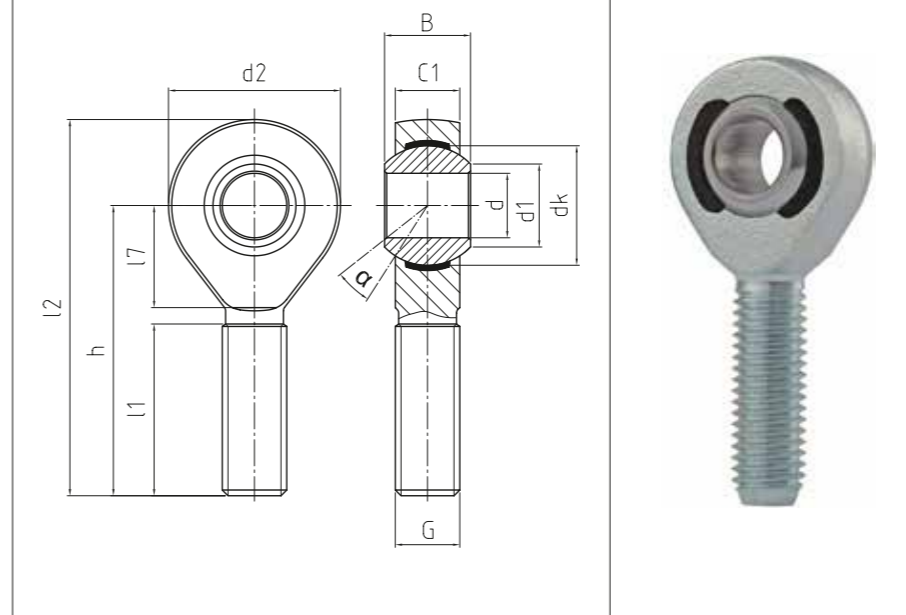

**BEM**

**Hochleistungs-Gelenkköpfe**  
 Heavy-duty rod ends

CLASSIC Line | X

Bestellnummer Order number			Abmessungen Measurements [mm]										Kippwinkel Tilt angle	Gewicht Weight	Tragzahlen Basic load rating		Radiale Lagerluft Radial clearance		
Typ Type	Rechtsgewinde Right hand thread	Linksgewinde Left hand thread	d	G	B	C1	h	d1	d2	dk	l1	l2	l7	α [°]	[kg]	dyn C [kN]	stat Co [kN]	CN [µm]	d
<b>BEM 05 - 20</b>	-501	-502	<b>5</b>	M 5	8	6	33	7,7	18	11,06	20	42	9	13	0,014	3,9	8,4	0 - 10	<b>5</b>
<b>BEM 06 - 20</b>	-501	-502	<b>6</b>	M 6	9	6,75	36	8,9	20	12,65	22	46	12	13	0,02	4,6	11,7	0 - 10	<b>6</b>
<b>BEM 08 - 20</b>	-501	-502	<b>8</b>	M 8	12	9	42	10,3	24	15,82	25	54	15	14,5	0,038	7	21,5	0 - 10	<b>8</b>
<b>BEM 10 - 20</b>	-501	-502	<b>10</b>	M 10	14	10,5	48	12,9	28	19	29	62	15	13,5	0,06	10,4	24,9	0 - 10	<b>10</b>
<b>BEM 12 - 20</b>	-501	-502	<b>12</b>	M 12	16	12	54	15,4	32	22,17	33	70	19	13	0,092	12,4	36,1	0 - 10	<b>12</b>
<b>BEM 14 - 20</b>	-501	-502	<b>14</b>	M 14	19	13,5	60	16,8	36	25,35	36	78	20	16	0,127	15,4	45,4	0 - 10	<b>14</b>
<b>BEM 16 - 20</b>	-501	-502	<b>16</b>	M 16	21	15	66	19,3	42	28,52	40	87	22	15,5	0,202	22,4	56,6	0 - 10	<b>16</b>
<b>BEM 18 - 20</b>	-501	-502	<b>18</b>	M 18 x 1,5	23	16,5	72	21,8	46	31,7	44	95	25	15	0,25	26,3	69,7	0 - 10	<b>18</b>
<b>BEM 20 - 20</b>	-501	-502	<b>20</b>	M 20 x 1,5	25	18	78	24,3	50	34,87	47	103	28	14,5	0,327	30,8	82,2	0 - 10	<b>20</b>
<b>BEM 22 - 20</b>	-501	-502	<b>22</b>	M 22 x 1,5	28	20	84	25,8	54	38,05	51	111	27	15,5	0,44	38,2	95,6	0 - 10	<b>22</b>
<b>BEM 25 - 20</b>	-501	-502	<b>25</b>	M 24 x 2	31	22	94	29,5	60	42,8	57	124	30	15	0,63	45,4	118,6	0 - 10	<b>25</b>
<b>BEM 30 - 20</b>	-501	-502	<b>30</b>	M 30 x 2	37	25	110	34,8	70	50,75	66	145	35	17	1,015	55	145,6	0 - 10	<b>30</b>

\* Auf Anfrage mit DURBAL-Coat Beschichtung (Zink-Nickel) und Edelstahl-Gelenkkugel  
 \* On request with DURBAL-Coat (Zinc-Nickel) and stainless steel joint ball